



LoRa gateway setup

RAK7268V2

RAK7268CV2



Product designed by Vivent Biosignals SA
Rue Mauverney 28, 1196 Gland, Switzerland
info@vivent.ch | +41 79 511 46 27
www.vivent-biosignals.com



LoRa gateway – User manual



Product designed by Shenzhen RAKwireless Technology Co., Ltd.
Room 506, Bldg B, New Compark, Pingshan First Road, Taoyuan
Street, Nanshan District, Shenzhen, Guangdong Province, The
People's Republic of China
www.rakwireless.com | inquiry@rakwireless.com | +86-755-86108311

1. Product overview

The RAK7268V2 / RAK7268CV2 WisGate Edge Lite 2 is part of the RAK Edge Series, offering flexible connectivity options to meet the needs of a wide range of IoT applications. Designed for indoor use, this gateway simplifies deployment with built-in Ethernet connectivity and onboard 2.4 GHz WiFi for easy configuration through the default WiFi AP mode. The RAK7268CV2 version additionally supports LTE uplink communication, offering optional cellular backhaul for remote deployments or environments requiring LTE connectivity.

2. Package content

- RAK7268V2 / RAK7268CV2 8-channel LoRa gateway
- RP-SMA LoRa antenna connector
- Mounting bracket with installation accessories
- Power adapter for 110/220V AC
- Quick Start Guide.



Reference photo.

Additional Hardware Required:

- Ethernet Cable (RJ-45 Port) for Ethernet connection
- A Windows/MacOS/Linux Computer – For configuration via Web UI
- NanoSIM Card (for LTE version) – Size: 12 x 9 x 0.67 mm

3. Hardware features

All hardware features of the device:

- **8 LoRa channels**
- Supports **2.4 GHz WiFi AP** for easy configuration
- 100M Base-T **Ethernet with PoE** (Power over Ethernet IEEE 802.3 af)
- **RP-SMA LoRa antenna** connector
- Multi-backhaul options with Ethernet, WiFi, and Cellular (only in RAK7268CV2)
- SD card for log backup and LoRa frame buffering (in case of backhaul failover)
- **Optional LTE Cat 4 network** (only in RAK7268CV2)
- Breathing light for visual monitoring the gateway's status

4. Device layout

All ports are located on the backside of the device.

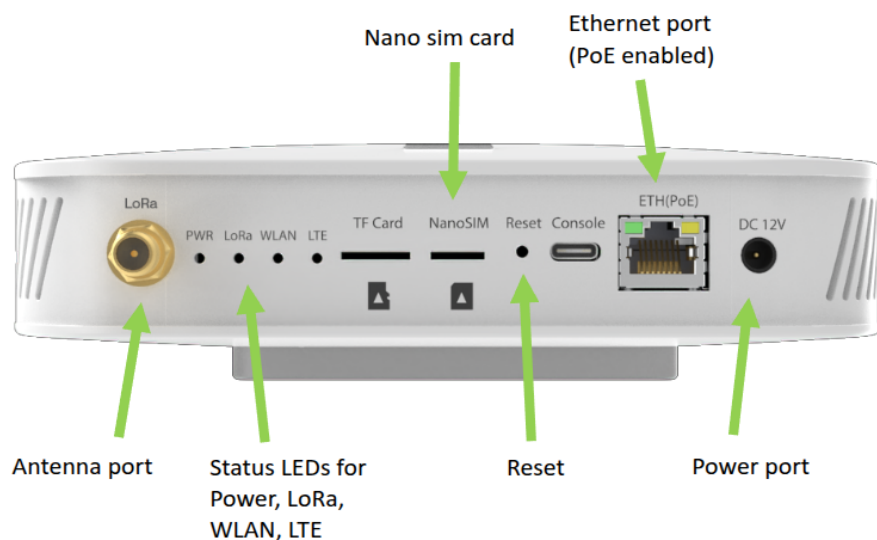

The gateway will automatically start when power is supplied to the gateway (either via the dedicated power port or via Power-over-Ethernet).

5. Installation

Install the gateway with the provided mounting bracket and installation accessories. Please check the provided QuickStart guide for details.

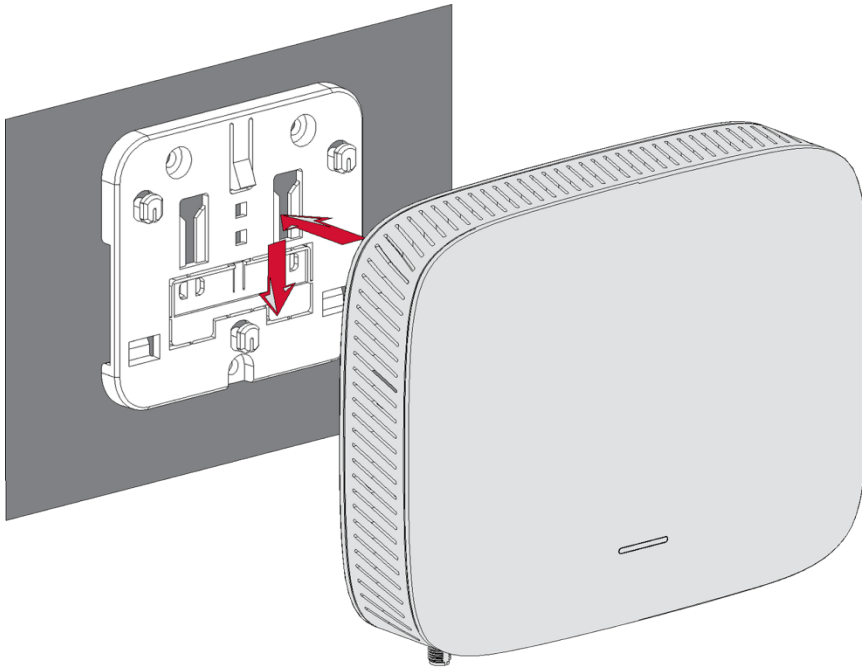

Connect the RP-SMA LoRa antenna before powering the gateway to avoid damaging sensitive electronics.

Installation requirements:

- **Antenna** must be pointing straight upwards and **must be installed before powering the gateway**
- Mount the gateway on a suitable wall or pole as high as feasible
 - > the higher up the gateway is mounted, the better the signal range/quality
 - > also minimizes interference with other plants

6. Powering On/Off

To turn on the device, connect the power adapter to the gateway's power port and to a suitable 110V/220V power outlet OR connect the gateway with a suitable Ethernet cable to a Power-over-Ethernet port (PoE (IEEE 802.3 af), 36-57 VDC).

- PWR status LED will light up
- LoRa status LED will light up
- WLAN status LED will light up

To switch off, disconnect the gateway from power.

7. LED Indicators Details

LED	Expected Status after Power-On	Description
PWR	ON (solid)	Power is connected; the gateway is powered.
Breathing LED	Red (fast blinking)	When the gateway is first powered on and not yet connected to the internet, the LED will show red with a fast blink to indicate a network issue.
	Blue (slow blinking)	Once the gateway successfully connects to the internet, the LED will switch to blue with a slow blink, indicating normal operation.
ETH	ON / Flickering	Ethernet mode is active and functional.
WLAN	ON / Flickering	WiFi AP mode is active and functional.
LoRa	ON / Flickering	Indicates the LoRa transceiver is operational and handling packets.
LTE (RAK7268CV2 only)	Fast flickering or slow idle blinking	LTE module is either transmitting data or searching for a network.

For more detailed LED behavior and additional indicators, refer to the RAK7268V2/RAK7268CV2 LED Indicators.

8. Access the gateway

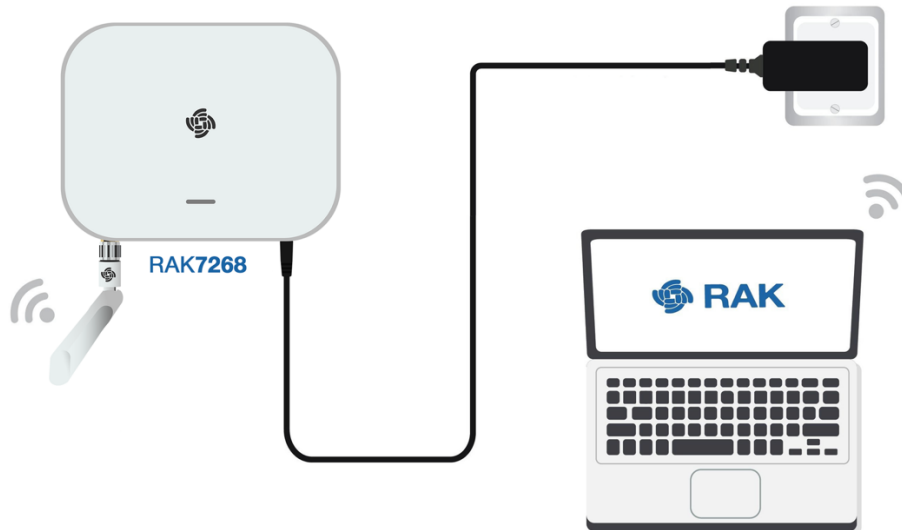

- The gateway provides its own Wi-Fi access point network. Connect to the gateway's WiFi. You can find the Wi-Fi SSID, named "RAK7268_XXXX" on your PC's Wi-Fi network list. "XXXX" is a number/letter combination from the last two bytes of the device's MAC address and unique to your device.
NOTE: No password is required to connect via WiFi.
- Open a web browser (Chrome, Firefox, Safari etc.) and enter the IP address: 192.168.230.1
- At WisGate configuration page login is always "root". On the first login, you must set a login password. The password must:
 - At least be 12 characters long
 - Has at least one special character (!"#\$%&'()*+,-./:;<=>?@[]^_`{|}~)
 - Has at least one number
 - Has at least one standard Latin letter (used in the English alphabet)

Initial access/configuration can also be done via direct Ethernet link. Please consult [RAK's setup guide](#) for more details.

9. Connect the Gateway to the Internet

To allow data transfer from sensors via the gateway, an active internet link is required.

To connect a gateway, you can use one of the 3 types of connections (you can enable more than one):

- WiFi,
- LTE (For LTE Version),
- Ethernet.

WiFi

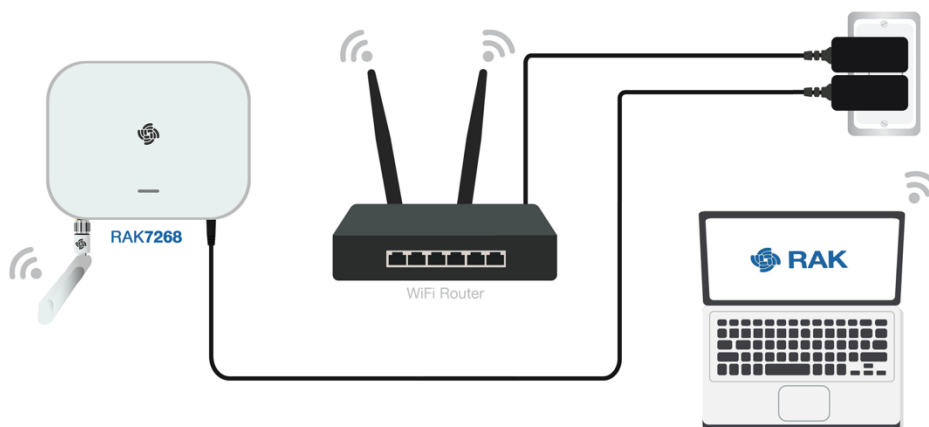

Example of WiFi linked gateway photo.

Log in to the Web UI, go to **Network > WAN > Wi-Fi**.

1. Expand the WiFi section and click on **Settings**. Ensure the Interface is enabled.
2. Click the **Scan** button to select your **ESSID**, or manually enter the ESSID of the network by clicking **Enter network (E)SSID manually**.
3. Choose the correct **Encryption** method and enter the appropriate **Key**.

NOTE: The gateway will reboot frequently throughout this procedure. Please ensure that you re-establish the connection to the gateway's WiFi access point.

LTE (For LTE Version)

If you are using the RAK7268CV2 model and have inserted a valid SIM card, the gateway will typically connect to the cellular network automatically.

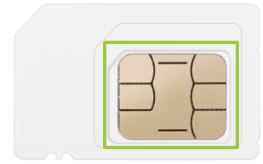

However, in some regions, manual APN configuration may be required depending on your mobile operator.

To manually configure APN and other LTE settings:

1. Log in to the Web UI and navigate to **Network > WAN > Cellular**.
2. Expand the Cellular section and click on **Settings**.
3. Enter the required **APN, username, password,** and **PIN code** if provided by your mobile operator.

Cellular settings

Network > cellular settings

General Tracking

LTE Network

Enabled Disabled

APN (optional)

User (optional)

Password (optional)

PIN code (optional)

Ethernet

Connect one end of an **Ethernet cable** to the gateway's **ETH(PoE)** port, and the other end to your router. You can either choose DHCP assignment (default) or a static IP address for this connection.

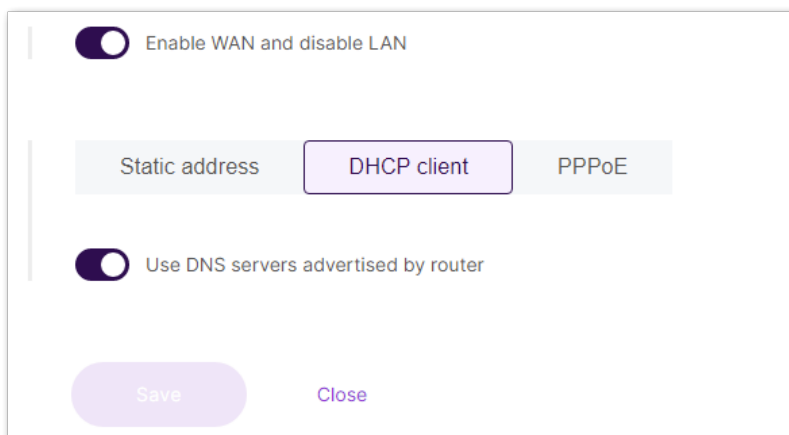

10. Firewall configuration

Our devices will connect to **ireland.svpn.vivent-biosignals.com** (Europe) or **ohio.svpn.vivent-biosignals.com** (Americas) servers. **The IP addresses of these servers are dynamic** and will change over time.

If using Ethernet or Wi-Fi connections with firewalls, please ensure the following ports are open for both TCP and UDP protocols.

- Port 53 (Incoming, TCP & UDP) – DNS (Dynamic Name Resolution) to resolve domain names like ohio.svpn.vivent-biosignals.com

NOTE: Our system is using Fully qualified domain names (FQDNs) which requires access to public DNS servers like Cloudflare (1.1.1.1) or Google (8.8.8.8)

- Port 123 (Incoming, TCP & UDP) – NTP (Network Time Protocol) for time synchronization
- Port 7999 (Outgoing, TCP & UDP) – OpenVPN access and configuration.

Please reach out to Vivent support (info@vivent.ch) to verify that the gateway is linked correctly.

11. Technical specification

Power: 12 VDC or 9–24 VDC (depending on model)

Ports: 100M Base-T Ethernet with PoE (IEEE 802.3 af)

LEDs: 4 status indicators

Power consumption: 3 W (typical)

Temperature range: from -10°C to +55°C

Operating Humidity: 0-95% RH non-condensing

Ingress protection: IP30

LoRa Frequency*: EU868/IN865/RU864/US915/AU915/
KR920/AS923-1-2-3-4/EU433/CN470

Weight: 0.3 kg

* depending on exact model

12. Declaration of Conformity

This device complies with part 15 of the FCC Rules. Operation is subject to the following two conditions: (1) This device may not cause harmful interference, and (2) this device must accept any interference received, including interference that may cause undesired operation.

A list of certifications is available under <https://docs.rakwireless.com/product-categories/wisgate/rak7268v2/datasheet/#certification>.

Please contact RAK Wireless directly for further questions concerning certifications.

12. Support

For assistance contact distributor or authorised Vivent representative or visit:

Vivent SA | Rue Mauverney 28 | 1196 Gland, Switzerland

Email: info@vivent.ch | Phone: +41 79 511 46 27



Give your crops a voice.
Grow Smarter. Grow Sustainable

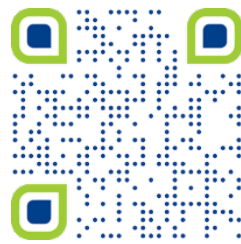

Vivent Biosignals SA
Rue Mauverney 28, 1196 Gland, Switzerland
info@vivent.ch | +41 79 511 46 27
www.vivent-biosignals.com

